

Only use floortube for correct outdoor installation:  
 For ROUND: Carefully cut adhesive sealing joint to size and mount in floortube collar as shown.  
 For SQUARE: Joint is ready made fit to collar.

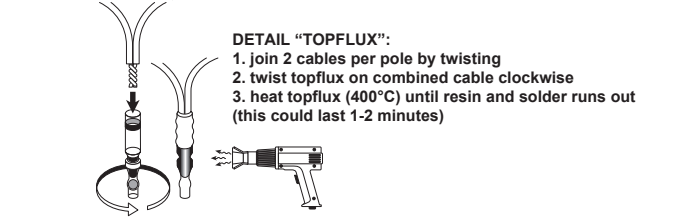
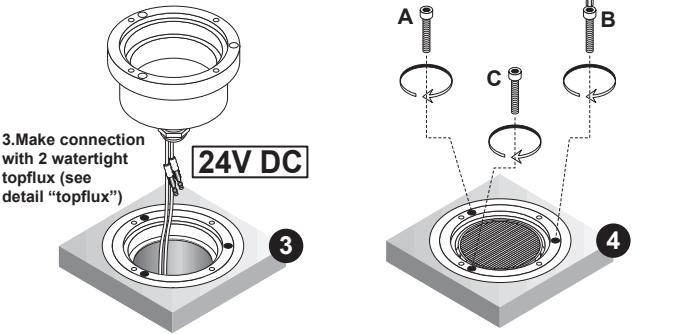
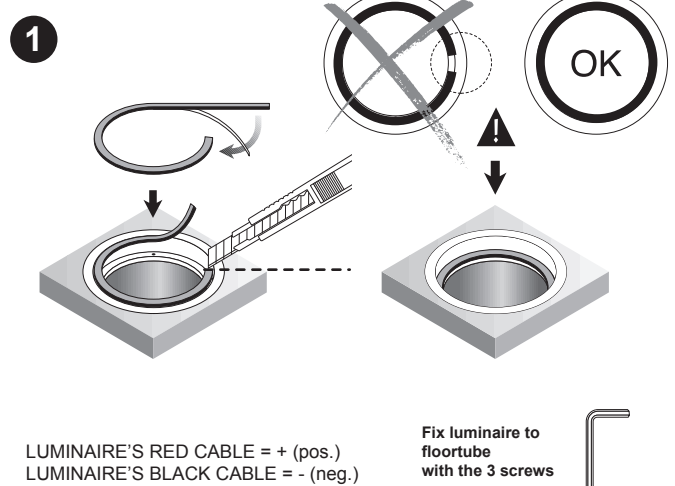

INSTALLATIE- EN ONDERHOUDSRICHTLIJNEN m.b.t. FABRIEKSGARANTIE.  
 1. DE VERBINDINGEN EN HET UITTESTEN VAN DEZE TOESTELLEN DIENEN ALTIJD TE GEBEUREN DOOR EEN ERKEND ELECTRO-INSTALLATEUR.  
 2. DEZE VERLICHTINGSTOESTELLEN MOETEN GEÏNSTALLEERD, VERBONDEN EN GETEST WORDEN VOLGENS DE NATIONAAL GELDENDE REGLEMENTEN OP DE ELECTRISCHE INSTALLATIES (BELGIË, A.R.E.I., DUITSLAND: DIN VDE 0100 TEIL 569 A2, ... DEZE OPSOMMING IS LOUWER INFORMATIEF).  
 3. DE TECHNISCHE GEBRUIKSANWEISINGEN MOET GEZIGN WORDEN ALS ONDERDEEL VAN DE ALGEMENE VERKOOPVOORWAARDEN VAN TAL N.V.  
 4. DE ELECTRO-INSTALLATEUR IS VERANTWOORDELIJK VOOR HET GEBRUIKEN VAN VOORSCHAKEL APPARATUUR DIE VOLDOET AAN DE GELDENDE CE EN EMC NORMEN.  
 5. VERRANG DE LAMP (EN) ALTIJD MET DE GROOTSTE ZORGE. ZIEZIJN UITERST BREEKBAAR.  
 6. OPGEPAST: PLAATS NOOIT DE LAMP MET BLOTE HANDEN, GEBRUIK ALTIJD EEN DOEK!

INSTRUCTIONS D'INSTALLATION ET D'ENTRETIEN A RESPECTER VIS-A-VIS DE LA GARANTIE.  
 1. LE PLACEMENT, LE RACCORDEMENT ET L'ESSAI DE CET APPAREIL DOIVENT TOUJOURS ETRE EFFECTUES PAR UN INSTALLATEUR ELECTRICIEN AGREE.  
 2. LES LUMINAIRES DOIVENT ETRE INSTALLEZ, BRANCHEZ ET TESTES SUVANT LE REGLEMENT NATIONAL SUR LES INSTALLATIONS ELECTRIQUES EN VIGUEUR (BELGIQUE, A.R.E.I., ALLEMAGNE: DIN VDE 0100 TEIL 569 A2, ... CETTE ENUMERATION EST INDICATIVE).  
 3. CE MANUEL D'INSTALLATION TECHNIQUE REPRESENTE UNE PARTIE DES CONDITIONS GENERALES DE VENTE DE TAL N.V.  
 4. L'ELECTRO-INSTALLATEUR EST RESPONSABLE POUR L'USAGE DE BALLASTS, TRANSFORMS, ... CONFORMES AUX NORMES CE ET EMC EN VIGUEUR.  
 5. REMPLACEZ TOUJOURS L'AMPOULE (LES AMPOULES) AVEC PRUDENCE. ELECS EST (SONT) TRES FRAGILE(S).  
 6. ATTENTION: NE JAMAIS REMPLACER L'AMPOULE AUX MANS NUES. UTILISEZ TOUJOURS UN CHIFFON!  
 INSTALLATION AND MAINTENANCE INSTRUCTIONS IN VIEW OF THE MANUFACTURER'S GUARANTEE.  
 1. THE CONNECTION AND TESTING OF THE DEVICES SHOULD ALWAYS BE PERFORMED BY A RECOGNIZED ELECTRICIAN.  
 2. THESE LIGHTING DEVICES NEED TO BE INSTALLED, CONNECTED AND TESTED FOLLOWING THE OFFICIAL NATIONAL INSTRUCTION GUIDE FOR ELECTRICAL INSTALLATIONS (BELGIUM, A.R.E.I., GERMANY: DIN VDE 0100 TEIL 569 A2, ... THIS ENUMERATION IS JUST AN INDICATION).  
 3. THIS TECHNICAL ENCLOSURE NEEDS TO BE ADDED TO THE GENERAL SALES CONDITION OF THE TAL N.V.  
 4. THE ELECTRO TECHNICIAN IS RESPONSIBLE TO USE BALLASTS, TRANSFORMERS, ... WHICH MEET THE VALID CE AND EMC RULES.  
 5. ALWAYS REPLACE THE LAMP (S) WITH UTMOST CAUTIONSNESS. THE LAMP (S) IS (ARE) VERY FRAGILE.  
 6. ATTENTION: NEVER REPLACE THE LAMP WITH BARE HANDS, ALWAYS USE A CLOTH.

MONTAGE- UND UNTERHALTUNGSANWEISUNGEN ZU BEACHTEN MIT BEZUG AUF DER GARANTIE.  
 1. DIE MONTAGE-, DER ANSCHLUSS UND DAS AUSTESTEN DER LEUCHTEN SOLL IMMER VON EINEM ZUSTAENDIGEN ELECTRO-INSTALLATEUR AUSGEFUHRT WERDEN.  
 2. DIESE LEUCHTEN MUESSEN INSTALLIERT, ANGEGLOSSEN UND GETESTET NACH DER ALLGEMEINEN NATIONALEN REGLEMENTATION NUBER DIE ELEKTRISCHE INSTALLATIONEN (BELGIEN, A.R.E.I., DEUTSCHLAND: DIN VDE 0100 TEIL 569 A2, ... DIESE AUFSTELLUNG GESCHICHT DURCH DEN PRAKTISCHEN TITEL UND KANN NICHT ALS LIMITIV ODER EXKLUATIV BETRACHTET WERDEN).  
 3. DIESE TECHNISCHE GEBRAUCHSANWEISUNG GEHORT ZU DEN ALLGEMEINEN VERKAUFSEBEDINGUNGEN VON TAL N.V.  
 4. DER ELECTRO-INSTALLATEUR IST VERANTWOORTLICH FUR DAS VERBINDEN VON CE UND EMC GEPURTE VORSCHAKELGERAETE.  
 5. DIE LAMPE(N) SOLL(EN) IMMER SEHR VORSICHTIG ERSAETZT WERDEN.  
 6. VORSICHT: MAN DARF NIE DIE LAMPE MIT DEN NACKTEN HAENDEN BERUEHREN. MAN SOLL IMMER EINEN TUCH BENUTZEN!

2 a. Outdoor installation with floortube.

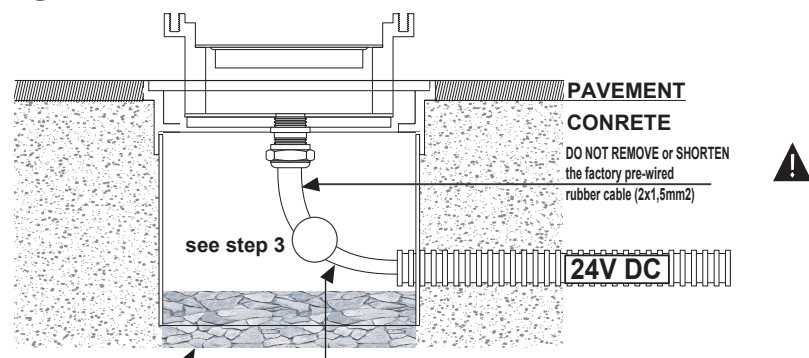

Leave enough spare cable to allow easy connection of luminaire  
 Leave some aggregate (gravel) to allow proper drainage of surface water.

2 b. Indoor installation can be done without floortube using cutouts on the right.

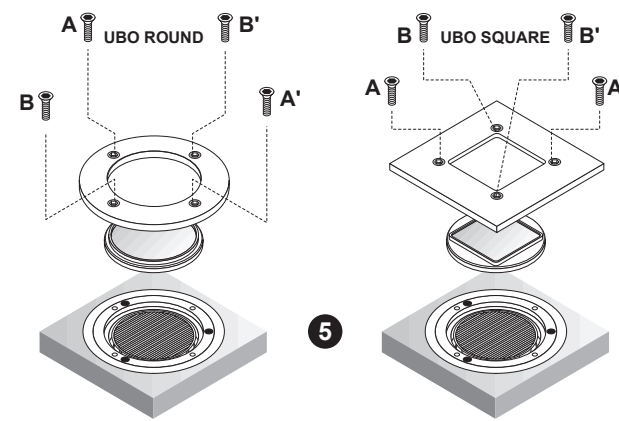
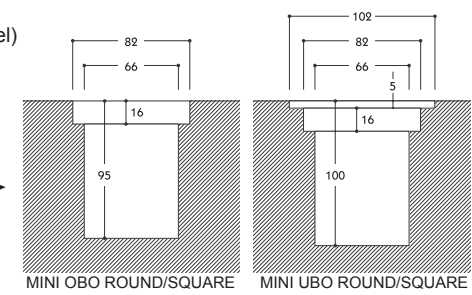

START-UP LUMINAIRE:  
 1. leave illuminated for 30min without covering disk for evacuation of ambient humidity.  
 2. close luminaire in operation and tighten 4 screws cross wise (AA'BB').  
 3. leave illuminated for 5 minutes and verify after extinction that 4 screws are fixed well.

ALWAYS DISCONNECT MAINS POWER SUPPLY FROM CONVERTER BEFORE SWITCHING "ON" LED LUMINAIRE TO PREVENT HOT PLUGGING ISSUES

GENERAL INFORMATION

lamptype	3 x 1W POWERLED
fitting	none
watt	3x1W
voltage	24V DC
symbol	
gear	Not incorporated
ip/class	IP67
application	Exterior (only in comb. with floortube)-Interior*
orientation	Floor mounted
dimmmable	PWM dimmable
weight	0.8

ACCESSORIES NEEDED

ref 366318		resp. floortube OBO ROUND / SQUARE
ref 366408		resp. floortube UBO SQUARE
ref 366308		resp. floortube UBO ROUND

	MATERIAL	TREATMENT	
*	STAINLESS STEEL	MARINE GRADE 316	Electrolytically Polished
	ANODISED ALU	AlMgSi 0,5	Technical Anodised